

Tsunami Pump[®]
your preferred water booster

**IMPROVED
 PERFORMANCE
 MORE
 DURABILITY**

CMH8
 S E R I E S



CMH8-25-K2*

**HIGH POWER
 WATER BOOSTING
 FOR HOTEL & MOTEL**

ECO FRIENDLY
 Save Water ♦ Save Energy



A robust pump designed to give higher performance and longer operating life. The CMH Series features Cast Iron inlets and outlets.

- High performance - quiet operation continuously rated.
- Supplied with lead, plug and start/stop switch (not hard-wired).
- CMH8 combines with UP-PC for an effective pressure system.
- Supports hotel, motel, hostel, public shower room, etc.

Supports up to

15-20 Shower Heads & Water Tabs



Low Maintenance



Energy Saving



Over Heating Protection



Anti-Rust Pump Shell



Less Noise Operation



Strong & Durable

www.csp.my



JAPAN Technology
 日本科技



CMH8-25-K2*



K2 Pressure Controller

Capable of simultaneously detecting both the pressure and the flow, as well as automatically managing the pump operation, stopping the pump in the case of water shortage to protect it from dry running, provides protection against loss of prime.



Optional Accessories

PT TAIWAN
Pressure Tank

Specifications

- Strong & durable
- Corrosion resistant
- Stainless steel pump construction
- Cast Iron inlets & outlets
- Motor protection IP55
- Thermal overload protection with single phase models
- Liquid temperature from 20°C to 70°C

PERFORMANCE TABLE

MODEL	P ₂ (kW)	Size(mm)										Weight (kg)
		Single-Phase					Three-Phase					
		L	L1	L2	B(In)	C(In)	L	L1	L2	B(In)	C(In)	
CMH8-15	0.75	355	99	108	G1½	G1¼	355	99	108	G1½	G1¼	15
CMH8-20-K2	1.0	355	99	108	G1½	G1¼	355	99	108	G1½	G1¼	18
CMH8-25-K2	1.50	420	129	138	G1½	G1¼	420	129	138	G1½	G1¼	20
CMH8-30	1.85	420	129	138	G1½	G1¼	420	129	138	G1½	G1¼	25
CMH8-35	2.20	510	159	168	G1½	G1¼	450	159	168	G1½	G1¼	30
CMH8-40	2.20	510	159	168	G1½	G1¼	450	159	168	G1½	G1¼	31
CMH12-15	1.50	390	99	108	G1½	G1½	390	99	108	G1½	G1½	18
CMH12-20	1.85	450	99	108	G1½	G1½	390	99	108	G1½	G1½	20
CMH12-25	2.20	480	129	138	G1½	G1½	420	129	138	G1½	G1½	24
CMH12-30	3.0						480	129	138	G1½	G1½	27

INSTALLATION STRUCTURE

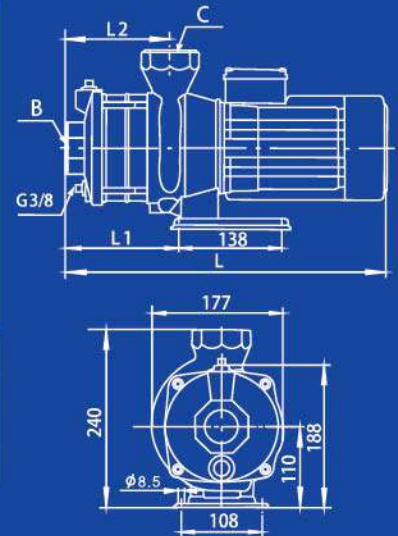

■ All models are available in Single Phase & Three-Phase spec.

PERFORMANCE CURVE

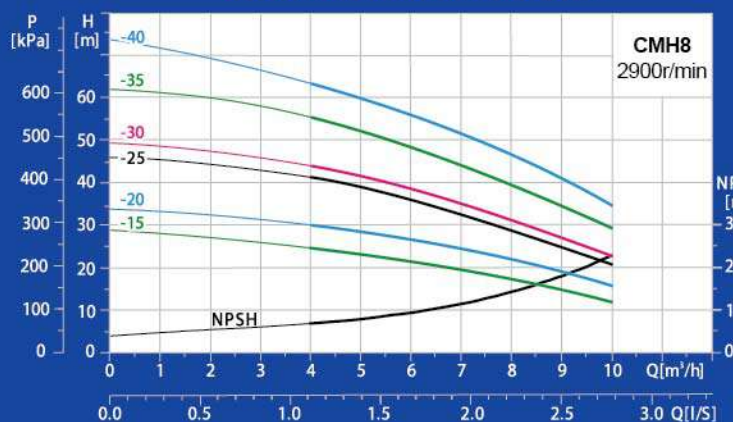

PERFORMANCE CURVE

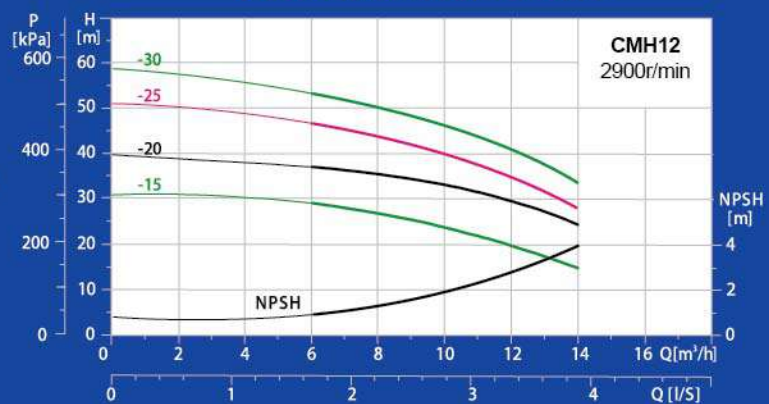

代理商 Authorized Distributor

ISO 9001



TUV
PRODUCT SERVICE
CERTIFIED
GERMANY

